



INSTRUCTIONS

Components

- 4 - Levelers
- 4 - 1/4-20 Bolts
- 4 - Glide Plugs

Tools Required

- #3 Phillips Screwdriver

Step 1

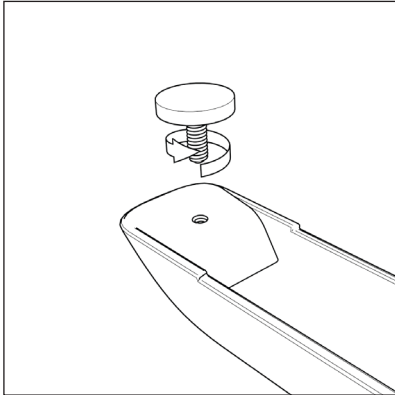

Remove the original glides from the base.

Step 2

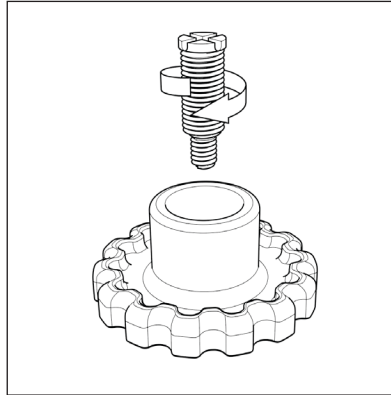

Thread the bolt into each leveler.

Step 3

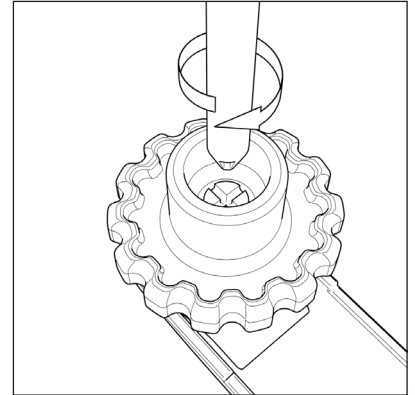

Mount the assembled levelers to the base using a #3 Phillips screwdriver.

Step 4

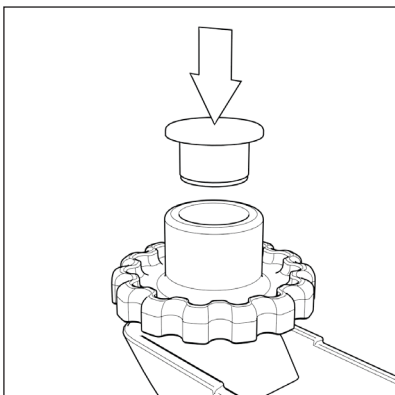

Insert the glide plug into each leveler.

Step 5

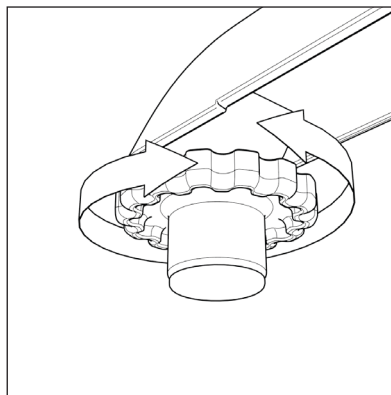

Turn all PronToes to the minimum height and flip your table base over.

Step 6

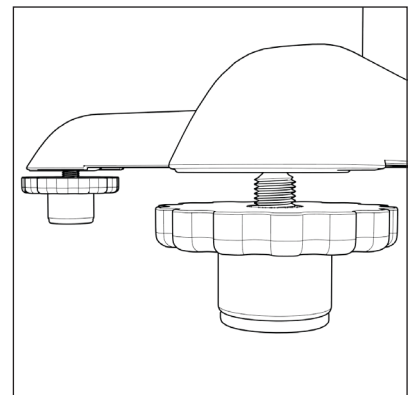

Adjust your table base by turning the PronToe until the base is level.

"Keeping you balanced"



Patent Pending